

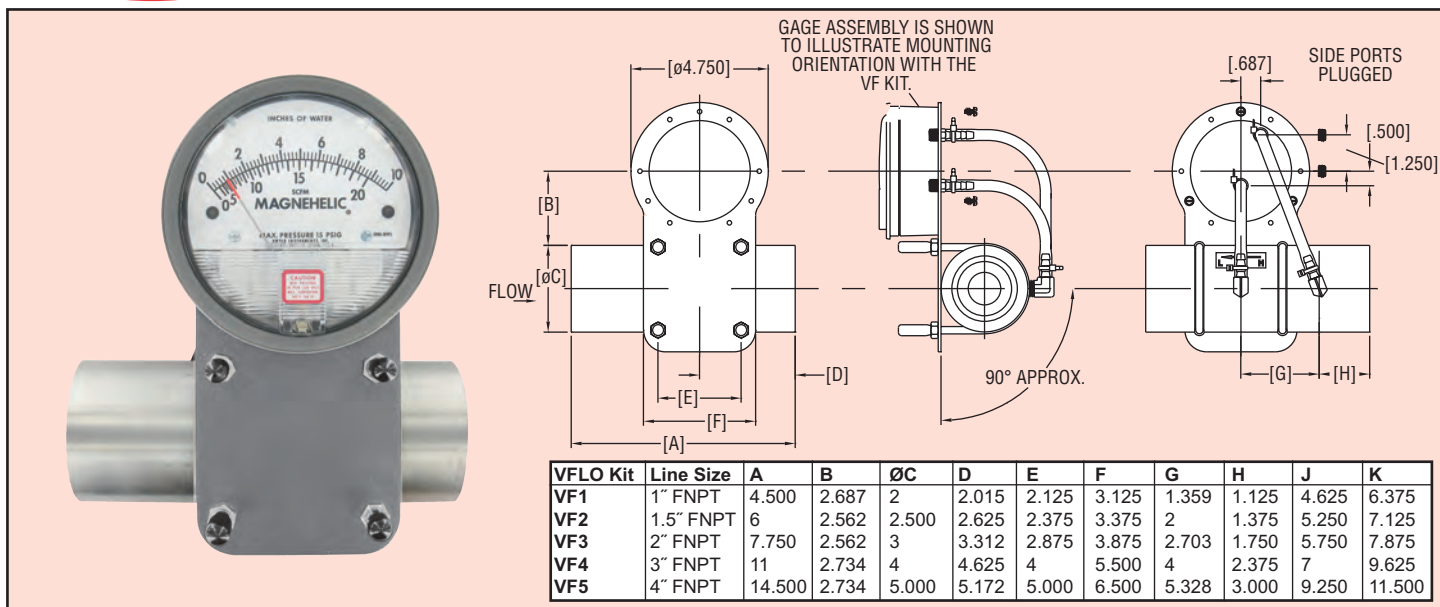

# Venturi Flowmeter with Magnehelic® Gage

±2.5% Accuracy, Dual Scale in SCFM & in w.c.



The Venturi Flow Meter with Magnehelic® Gage is fabricated from aluminum and has a gradual Venturi profile to reduce pressure losses through the meter. Flexible connections enable the meter to be used in vertical or horizontal applications. The Magnehelic® gage provides a large, clear and accurate display of your differential pressure reading. Each meter is calibrated at standard atmospheric conditions. The dual scale reads in SCFM and in w.c. The meter is supplied with easy to read reference charts for various flow conditions. It is available in line sizes from 1" to 4" and can handle vacuum and pressure applications.

**Series 2000, Magnehelic® Differential Pressure Gage**  
To Create Venturi Model, add option from chart to end of 2000.  
Ex: 2000-10VF1 for 10 in w.c. & 20 SCFM of Air Scale with 1" Venturi Flow Tube

### ACCESSORIES

- MV4-LM1**, Mini brass ball valve with lever handle.  
1/8" F X 1/8" MNPT
- MV4-LM2**, Mini brass valve with tee handle.  
1/8" M X 1/8" FNPT
- MV5-WM1**, Mini brass ball valve with wedge handle.  
1/8" M X 1/8" FNPT

### SPECIFICATIONS

- Service:** Air and non-combustible, compatible gases. (Natural gas option available).
- Wetted Materials:** Aluminum, silicone, acrylic, polycarbonate, high carbon steel, low carbon steel, brass, paper, acrylic paint, enamel paint, alkyd coating, nickel plate, zinc plate, helser FC, 300 series stainless steel, PTFE, Loctite® AV sealant, commercial black rubber, neoprene, samarium cobalt, nickel alloy steel cover, beryllium copper.
- Housing:** Die cast aluminum case and bezel, with acrylic cover. Exterior finish is coated gray to withstand 168 hour salt spray corrosion test.
- Accuracy:** ±2.5% FS.
- Pressure Limits:** -20" Hg to 15 psig (-0.677 bar to 1.034 bar); MP option: 35 psig (2.41 bar). For applications with high cycle rate within gage total pressure rating, next higher rating is recommended.
- Overpressure:** Relief plug opens at approximately 25 psig (1.72 kPa).
- Temperature Limits:** 20 to 140°F (-6.67 to 60°C).
- Size:** 4" (101.6 mm) diameter dial face.
- Mounting Orientation:** Diaphragm in vertical position. Consult factory for other position orientations.
- Process Connection:** Female NPT of nominal line size. (See chart).
- Weight:** Gage only: 1 lb 2 oz (510 g), MP & HP 2 lb 2 oz (963 g). Venturi: see chart.

Option Number	Range	Line Size	Weight (Not Including Gage) lb (kg)
2000-10VF1	0-10 in w.c. & 0-20 SCFM air	1"	3 (1.36)
2000-20VF1	0-20 in w.c. & 0-30 SCFM air	1"	3 (1.36)
2000-40VF1	0-40 in w.c. & 0-40 SCFM air	1"	3 (1.36)
2000-10VF2	0-10 in w.c. & 0-50 SCFM air	1-1/2"	4.5 (2.04)
2000-20VF2	0-20 in w.c. & 0-70 SCFM air	1-1/2"	4.5 (2.04)
2000-40VF2	0-40 in w.c. & 0-100 SCFM air	1-1/2"	4.5 (2.04)
2000-10VF3	0-10 in w.c. & 0-85 SCFM air	2"	6 (2.72)
2000-20VF3	0-20 in w.c. & 0-120 SCFM air	2"	6 (2.72)
2000-40VF3	0-40 in w.c. & 0-160 SCFM air	2"	6 (2.72)
2000-10VF4	0-10 in w.c. & 0-200 SCFM air	3"	11 (4.99)
2000-20VF4	0-20 in w.c. & 0-290 SCFM air	3"	11 (4.99)
2000-40VF4	0-40 in w.c. & 0-395 SCFM air	3"	11 (4.99)
2000-10VF5	0-10 in w.c. & 0-350 SCFM air	4"	18 (8.16)
2000-20VF5	0-20 in w.c. & 0-500 SCFM air	4"	18 (8.16)
2000-40VF5	0-40 in w.c. & 0-675 SCFM air	4"	18 (8.16)

Loctite® is a registered trademark of Henkel Corporation